

## HYDRAULIC STRUT

### TABULATED DATA Effective February 10, 2017

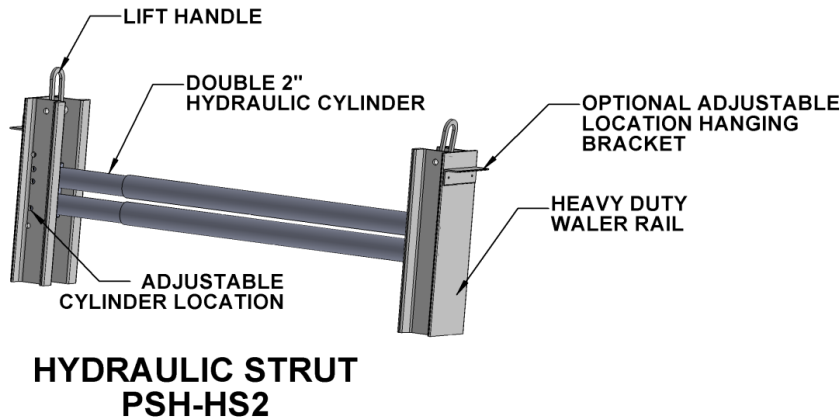
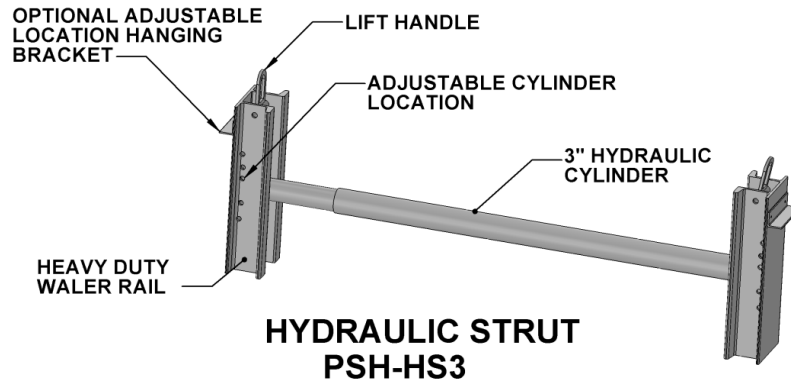

### Contents

Description .....	2
General Information for use of Pacific Shoring 3” Hydraulic Strut .....	2
Classification of Soil Types .....	3
Hydraulic Strut Allowable Loading.....	4
Vertical Hydraulic Shore Selection Guide.....	5
Typical Hydraulic Strut Applications .....	6

### Description

The Pacific Shoring Hydraulic Strut is a 3” aluminum hydraulic cylinder mounted on 18” to 24” long heavy-duty waler rails. The assembly also has an optional angle bracket so that the strut can be set on a wale and position the cylinder at the wale web. Lift brackets are attached to the assembly for the purpose of setting the strut and providing vertical safety support so that the strut cannot fall into the excavation. The waler rail has hole positions that allow the cylinder to be centered on different depth steel wales such as HP14”, HP12”, W12” and W14” beams. Strutting should be centered on wale webs so as to prevent development of eccentric moments in addition to the axial forces that the strut delivers to the wale.

This Hydraulic Strut is generally used on waled excavation support systems, and directly on piles in pile and plate shoring systems. The Pacific Shoring Hydraulic Strut can be used in any situation where hydraulic force is needed provided it is safely secured from kickout. In all situations, a competent person should determine that the strut is properly set and fixed into position.

### General Information for use of Pacific Shoring 3” Hydraulic Strut

1. The Pacific Shoring Hydraulic Strut tabulated here is based on requirements of Federal OSHA 29CFR, Part 1926, Subpart P-Excavations and Trenches

**1926.652(c)(2)**-Option (2) - Designs Using Manufacturer's Tabulated Data.  
1926.652(c)(2)(i) -Design of support systems, shield systems, or other protective systems that are drawn from manufacturer's tabulated data shall be in accordance with all specifications, recommendations, and limitations issued or made by the manufacturer.

All provisions of Subpart P apply when utilizing this tabulated data. The contractor’s competent person shall use this data to select allowable loading, allowable trench width and strut configuration. The competent person utilizing this tabulated data shall be experienced and knowledgeable of all requirements of Subpart P, and trained in the use and safety procedures for shoring applications.

2. Strut loading shall be determined by an engineer using acceptable excavation support design principals or a competent person that has determined the soil type and condition in accordance with OSHA Appendix A, Soil Classification. Classification shall be just prior to installing the strut. Soil conditions may change at a later date and require reevaluation of the strength and allowable depth.

3. After strut loads are determined, the engineer or competent person shall decide how to install the hydraulic shore so that the tabulated loads and trench widths for the strut are not exceeded.
4. The depth and spacing given in **Table 1** and **Table 2** governs the use of Pacific Shoring Hydraulic Struts and not tabulations given by other manufacturers. This Tabulated data applies exclusively to Hydraulic Struts manufactured by Pacific Shoring LLC. Any alterations to the Hydraulic Struts or variance from this tabulated data shall be indicated in a site-specific plan prepared and approved by a registered engineer.
5. When used in excavations the faces of excavations shall be vertical so that the shoring piles and wales are vertical and horizontal to the strut.
6. Pacific Shoring Hydraulic Struts may be used in any situation where axial load strutting is needed. The strut shall be securely attached with the bearing surface of the strut in the same plane as the bearing surface it is being attached to.
7. The strut shall always be secured so that it cannot fall down vertically due to gravity forces. In addition to the angle bracket hanger, a secondary tie off cable or chain shall be used to prevent it from falling on workers below.

## **Classification of Soil Types**

1. Soil classification shall be in accordance with OSHA Appendix A and classified just prior to installing hydraulic shores. Soil conditions may change at a later date and require hydraulic vertical shores to be reset at a different spacing.
2. The equivalent weight of OSHA soil types\* is assumed to be as follows:
  - OSHA Type “A” Soil                      25 PSF per ft of depth
  - OSHA Type “B” Soil                      45 PSF per ft of depth
  - Type “C-60” Soil                         60 PSF per ft of depth\*\*
  - OSHA Type “C” Soil                      80 PSF per ft of depth

\* These equivalent weights were adapted from OSHA 1926 Subpart P App C, Timber Shoring for Trenches, Tables C-1.1, C-1.2, and C-1.3

\*\* Type C-60 soil is not identified or classified in OSHA Appendix A3. Type C-60 soil is soil that does not qualify as OSHA Type A, or Type B, can be cut with vertical walls and will stand up long enough to safely insert and pressurize the hydraulic shore.

## Hydraulic Strut Allowable Loading

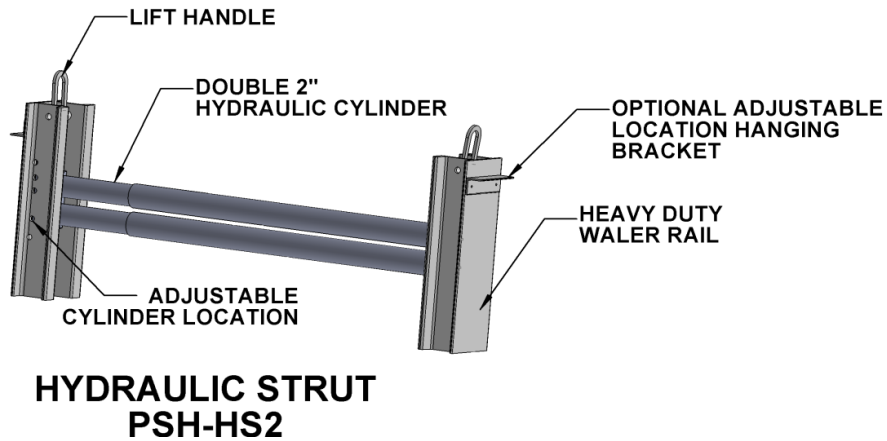
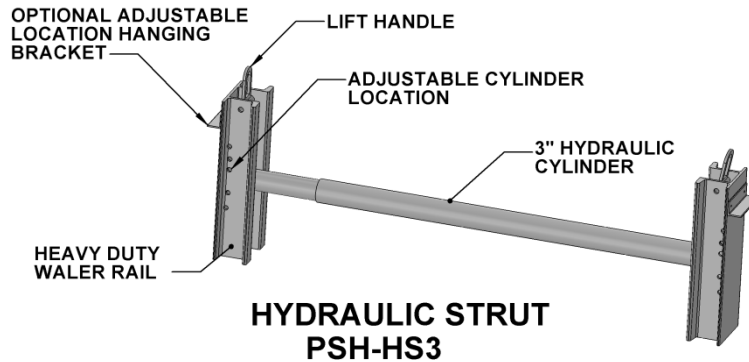

Table 1: Allowable Loads for Hydraulic Strut				
Model	Allowable Load (lbs)			
PSH-HS-3	3" Cylinder			
	Oversleeve	Extension Range (ft)		
		12	15	18
	4" Round x 3/16" Aluminum Oversleeve	40,000	20,000	12,000
4" Square x 3/16" Steel Oversleeve	40,000	40,000	30,000	18,000
PSH-HS-2	Allowable Load (lbs)			
	2" Cylinder			
	Oversleeve	Extension Range (ft)		
		8	12	15
3" Round x 3/16" Aluminum Oversleeve	40,000	24,000	12,000	8,000
3" Square x 3/16" Steel Oversleeve	40,000	40,000	21,000	12,000
Rails	18" or 24" Heavy Duty Waler Rail			

- Notes:** 1. Interpolation between cells in this table is allowed.  
 2. For 3 inch cylinders, loads listed are per cylinder. For 2 inch cylinders, loads are per double cylinder pack.

## Vertical Hydraulic Shore Selection Guide

Table 2: 3" Vertical Hydraulic Shore Selection Guide							
Depth of Trench	Hydraulic Cylinder Requirements						Sheeting
	Maximum Horizontal Spacing (ft)	Maximum Vertical Spacing (ft)	Cylinder Oversleeve Required per Width of Excavation (ft)				
			0-8	8-12	12-15	15-20	
Type 'A' Soil							
to 10'	8	4	OS1	OS1	OS2	OS2	Note 2
10' to 15'	8	4	OS1	OS1	OS2	OS2	Note 2
15' to 20'	8	4	OS1	OS1	OS2	OS2	Note 2
20' to 25'	8	4	OS1	OS1	OS2	OS2	Note 2
Type 'B' Soil							
to 10'	8	4	OS1	OS1	OS2	OS2	Note 2
10' to 15'	8	4	OS1	OS1	OS2	OS2	Note 2
15' to 20'	8	4	OS1	OS1	OS2	OS2	Note 2
20' to 25'	7	4	OS1	OS1	OS2	OS2	Note 3,4
Type 'C-60' Soil							
to 10'	8	4	OS1	OS1	OS2	OS2	Note 3
10' to 15'	8	4	OS1	OS1	OS2	OS2	Note 3
15' to 20'	7	4	OS1	OS1	OS2	OS2	Note 3
20' to 25'	5	4	OS1	OS1	OS2	OS2	Note 3,4
OS1: 4" Round x 3/16" Aluminum Oversleeve							
OS2: 4" Square x 3/16" Steel Oversleeve							

### Notes

- Soil shall first be classified in accordance with OSHA Appendix A Soil Classification for use with this selection guide. Type C-60 soil is OSHA Appendix A Type C soil that will stand up long enough to install the hydraulic shores.
- Sheeting is required at any depth whenever sloughing or raveling occur. If sloughing or raveling occurs between sheeting, decrease spacing until it is prevented. See **Table 3** for allowable sheeting. Sheeting may be attached to jack or set into trench separately.
- Sheeting is required at this depth.
- Sheeting must extend to the bottom of the excavation.
- This tabulation includes lateral loading from equipment weighing 20,000 lbs or less and a maximum 2 ft high spoil pile set back a minimum of 2 ft. The competent person shall determine the effect of all other surcharge loads and reduce hydraulic shore spacing as required to resist those loads.

Table 3: Allowable Sheeting			
Plywood		Other Materials	
3/4" Finn Form		1/2" Thick Steel Plate 4x8ft	
3/4" Omni Form		Steel Sheet Piling	
3/4" Plyform, Class 1 Exterior		Aluminum Sheet Piling	
3/4" HDO, High Density Overlay		Buildable Box Panels	
3/4" 14 Ply Artic White Birch			
1-1/8" CDX			
2 sheets of 3/4" CDX			
Timber Lagging Set Horizontal			
Thickness	Soil Type/Span		
	A	B	C-60
2"	4ft		
3"	5ft	4ft	
4"	8ft	6ft	4ft
DF#2 or Oak			

## Typical Hydraulic Strut Applications

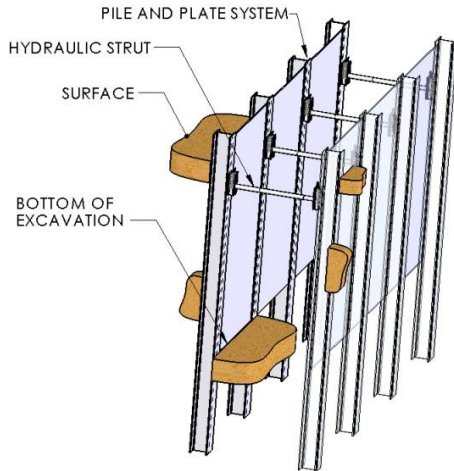

**Figure 1** Pile and Plate System with Strutting at Piles

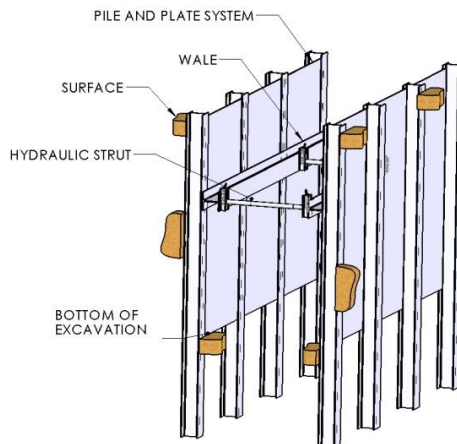

**Figure 2** Pile and Plate with Wale and Strut



**Figure 3** Waler Rail Systems