

HEAVY DUTY HYDRAULIC WALER RAIL SYSTEM

TABULATED DATA
Effective August 25, 2015

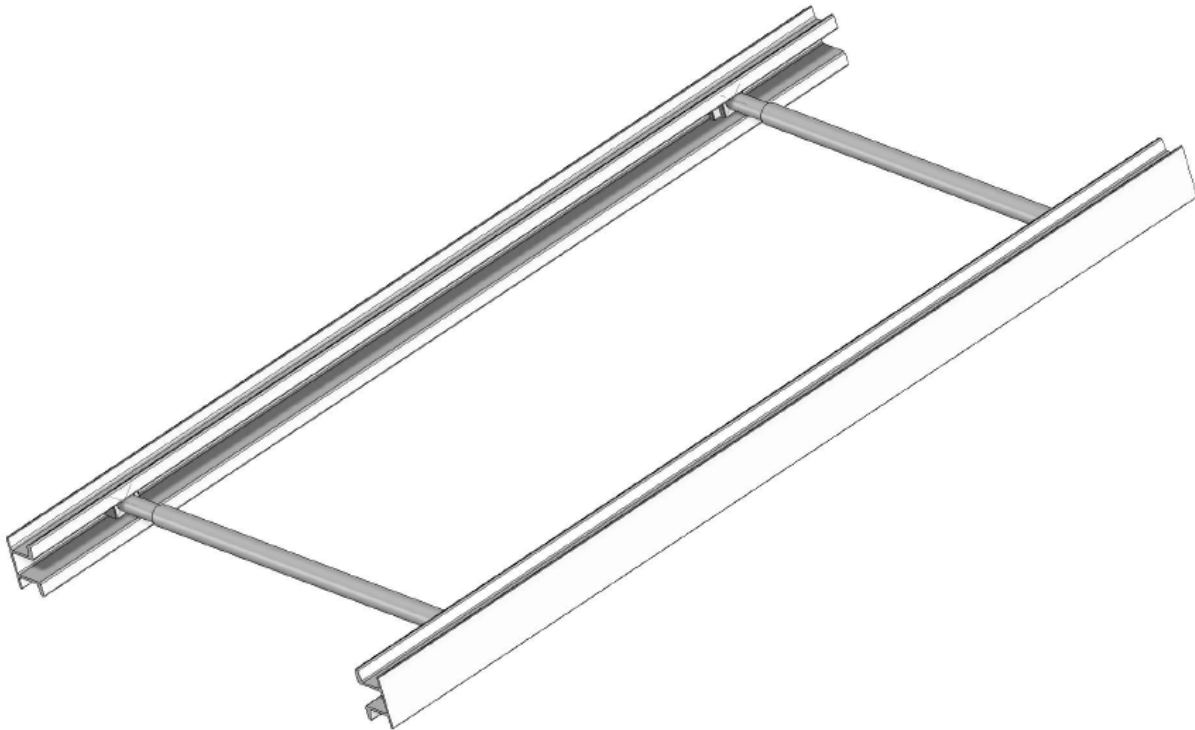

PSH

PACIFIC SHORING, LLC
265 Roberts Avenue
Santa Rosa, Ca. 95407
(707) 575-9014



Construction Engineering Resource
1837 Wright Street
Santa Rosa, Ca. 95404
jmtengr2@aol.com
(707) 484-4704

Contents

DESCRIPTION.....	2
GENERAL INFORMATION FOR USE OF WALER RAILS AND SHEETING	3
CLASSIFICATION OF SOIL TYPES	4
WALER RAIL SELECTION GUIDE.....	5
General Notes.....	5
Table Notes	6
Installation Notes	7
Waler Rail Model, Depth, and Width Tables	8
Waler Rail Geometric Properties.....	15
WALER RAIL SYSTEM SHORE INSTALLATION AND REMOVAL PROCEDURE.....	16

DESCRIPTION

The Pacific Shoring Heavy Duty Hydraulic Waler Rail System is generally used where it is not practical to use vertical hydraulic shoring. The strength of the waler rail allows greater horizontal spacing of the hydraulic cylinders. The maximum vertical spacing of the wale and cylinders is 4 ft the same as with vertical shoring; however, the horizontal spacing can be as much as 10 ft. Waler rails are always used with sheeting. Vertical sheeting such as timber lagging can be driven behind the wales as the excavation proceeds to depth. This method is particularly useful in soft clays or running sand.

Rail length can vary from 6 ft to 16 ft and horizontal cylinder spacing as much as 10 ft. Allowable trench widths are from 4 ft to 15 ft. Maximum depth is to 20 ft. Site specific designs beyond these parameters are achievable when using design by a registered engineer.

GENERAL INFORMATION FOR USE OF WALER RAILS AND SHEETING

1. The Heavy Duty Waler Rail Shoring System tabulated here is based on requirements of Federal OSHA 29CFR, Part 1926, Subpart P-Excavations and Trenches

1926.652(c)(2)-Option (2) - Designs Using Manufacturer's Tabulated Data.
1926.652(c)(2)(i) -Design of support systems, shield systems, or other protective systems that are drawn from manufacturer's tabulated data shall be in accordance with all specifications, recommendations, and limitations issued or made by the manufacturer.

All provisions of Subpart P apply when utilizing this tabulated data. The contractor's competent person shall use this data to select allowable trench depth, vertical and horizontal shore spacing and plywood use requirements for the Pacific Shoring Waler Rail System. The competent person utilizing this tabulated data shall be experienced and knowledgeable of all requirements of Subpart P, and trained in the use and safety procedures for aluminum hydraulic shores and waler rails.

2. Use of this tabulated data is dependent on first classifying the soil in accordance with OSHA Appendix A, Soil Classification. Classification shall be just prior to installing shoring. Soil conditions may change at a later date and require shores to be reset at a different spacing.
3. Heavy Duty Waler Rail System Shoring is tabulated based on the effect of a 20,000 lb surcharge load set back 2 ft from the edge of the trench and the equivalent weight effect of the OSHA soil type, see classification of soil types, 2.
4. The depth and spacing given in **Table 1** governs the use of Pacific Shoring Heavy Duty Waler Rails and not tabulations given in OSHA Appendix C. This tabulated data applies exclusively to Heavy Duty Waler Rails manufactured by Pacific Shoring LLC. Any alterations to the shores or variance from this tabulated data shall be indicated in a site-specific plan prepared and approved by a registered engineer.
5. Faces of excavations shall be straight and vertical and there shall be contact with the soil behind the sheeting near each cylinder. Intermittent gaps directly behind the sheeting and the soil shall not exceed 6".
6. When the lower portion of the trench is shored and the top is sloped the shoring and sheeting shall extend a minimum of 18" above the top of the vertical trench wall and the sloping beyond shall be in accordance with OSHA sloping and benching for the soil type encountered.
7. HD Hydraulic Waler Rails shall be installed and removed from outside the trench, see installation and removal procedure.
8. The competent person shall continually monitor the shored excavation for changed conditions such as water seepage, soil movement cracks at the surface, sloughing or raveling, proper surcharge load weight less than 20,000 lbs and setback a minimum of 2 ft, and damaged shores.
9. Workers shall always enter, exit, and work inside the shored area of the trench.

CLASSIFICATION OF SOIL TYPES

2.1 Soil classification shall be in accordance with OSHA Appendix A and classified just prior to installing Waler Rail Systems. Soil conditions may change at a later date and require waler rails to be reset at a different spacing.

2.2 The equivalent weight of OSHA soil types* is assumed to be as follows:

- OSHA Type “A” Soil 25 PSF per ft of depth
- OSHA Type “B” Soil 45 PSF per ft of depth
- Type “C-60” Soil 60 PSF per ft of depth**
- OSHA Type “C” Soil 80 PSF per ft of depth

* These equivalent weights were adapted from OSHA 1926 Subpart P App C, Timber Shoring for Trenches, Tables C-1.1, C-1.2, and C-1.3

** Type C-60 soil is not identified or classified in OSHA Appendix A

2.2 Type C-60 soil is soil that does not qualify as OSHA Type A, or Type B, can be cut with vertical walls and will stand up long enough to safely insert and pressurize the hydraulic shore.

2.3 Waler Rails may be used in OSHA Type C-80 Soil

WALER RAIL SELECTION GUIDE

General Notes

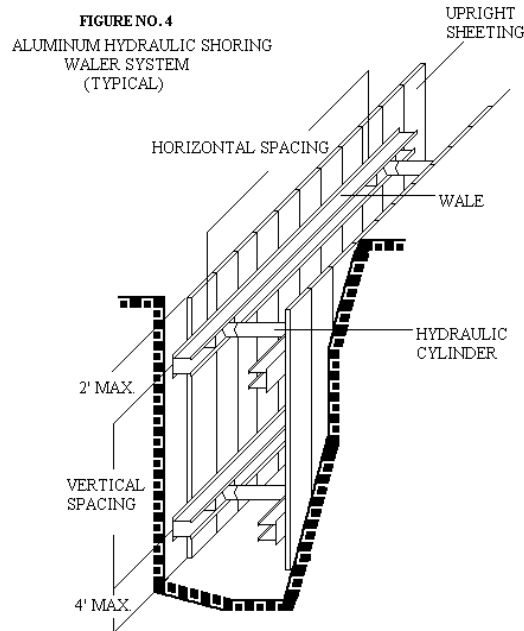

The following tables are to be used by a competent person when selecting a waler rail system for excavation shoring. Selection steps are as follows:

1. Determine excavation parameters
 - depth
 - length
 - width
 - clearance needed between cylinders
 - waler configuration, 2 cylinders or 3, cylinders

2. Determine OSHA soil type, A&B, C-60, or C-80

3. Go to the table as follows;
 - **Table 1-2** Cylinder Waler Rail Dimensions
 - **Table 2-2** Cylinder Waler Rail for OSHA Type A&B Soil
 - **Table 3-2** Cylinder Waler Rail for OSHA Type C-60 Soil
 - **Table 4-2** Cylinder Waler Rail for OSHA Type C-80 Soil
 - **Table 5-3** Cylinder Waler Rail Dimensions
 - **Table 6-3** Cylinder Waler Rail for OSHA Type A & B Soil
 - **Table 7-3** Cylinder Waler Rail for OSHA Type C-60 Soil
 - **Table 8-3** Cylinder Waler Rail for OSHA Type C-80 Soil
 - **Table 9-2** Cylinder Light Duty Waler Rail dimensions

- **Table 10-2** Cylinder Light Duty Waler Rail for OSHA Type A & B Soil
 - **Table 11-2** Cylinder Light Duty Waler Rail for OSHA Type C-60 Soil
 - **Table 12-3** Cylinder Light Duty Waler Rail dimensions
 - **Table 13-3** Cylinder Light Duty Waler Rail for OSHA Type A & B Soil
 - **Table 14-3** Cylinder Light Duty Waler Rail for OSHA Type C-60 Soil
4. Enter **Table 1** or **5** to determine heavy duty rail dimensions and model.
Enter **Table 9** or **12** to determine light duty rail dimensions and model
 5. Enter proper table for number of cylinders and soil type
 - At maximum planned depth, find model number and then read required cylinder size and sheeting requirements
 - Vertical spacing is always 2 ft maximum from the top, 4 ft maximum between shores and maximum of 4 ft from the bottom.
 - Sheeting is always required; however, it varies from spaced plywood or timber to tight spaced timber 3 to 4" thick as the soil gets worse.

Note - Custom rail and cylinder spacing are available upon request. Use of all custom designed systems is to be in accordance with OSHA [1926.652\(c\)\(4\)](#) Option (4) - Design by a registered professional engineer.

Table Notes

Cylinder Notes:

1. 2" diameter aluminum cylinders shall have a 3" x 3/16" wall aluminum oversleeve that is the full-retracted length of the cylinder.
2. In trenches 12 ft and wider, 2" cylinders shall have a 3.5 x 3.5" x 3/16" steel tube oversleeve installed over the 3" aluminum oversleeve.
3. 3" cylinders have a 4" x 3/16" wall aluminum oversleeve that shall be used in all trenches over 8 ft wide

Sheeting Notes:

Table 1A Bending Properties for OSHA Plywood Sheeting and Polypropylene Sheets

Material	Grade Stress Level	Effective Section Modulus KS	Allowable Bending F _b
1-1/8"-2.4.1 int APA Plywood	S-2	0.840 in ³ /ft	1100 psi
Finland Form 3/4" All-Birch 1/2" Polypropylene	S-1	0.4826	3600 psi

1. Plywood -**Table 1A** sheets are acceptable
2. 2x8 timber lagging @ 24
3. 3x8 timber lagging @ 24
4. 3x8 timber lagging tight
5. 4x8 timber lagging tight
6. Extend timber lagging 24" below base of excavation or bottom wale shall be within 24" of bottom of excavation
7. Timber lagging shall be either Douglas Fir # 1 and better or Mixed Oak # 1 and better, s4s or timber dimensions

Installation Notes

Waler Rails are generally set using two different methods;

1. Set in pre-excavated hole
2. Set as excavation is being dug, (hand dug from inside)

Method 1

1. Attach sling to all wale sets being used in the hole stacked one on top of the other. Connect hydraulic hose to top set, and lower stack into the hole until top wale is at proper height
2. Drop sheeting behind waler rail
3. Pressurize top wale cylinders and to pump green zone
4. Lower remaining stack to next wale location and pressurize next wale set. Worker may be on ladder between first and second wale in order to change hydraulic hose connection.
5. Repeat to last wale location

Method 2

1. Excavate maximum 4 ft deep or to unstable soil depth as determined by competent person
2. Set wale stack inside excavation.
3. Stack sheeting behind wale frames and pressurize first wale set.
4. Excavate to next level, maximum 4 ft or to unstable soil, (sloughing or raveling), allowing waler sets to drop down.
5. Drive sheeting down behind waler-pressurize rails as excavation proceeds.

Waler Rail Model, Depth, and Width Tables

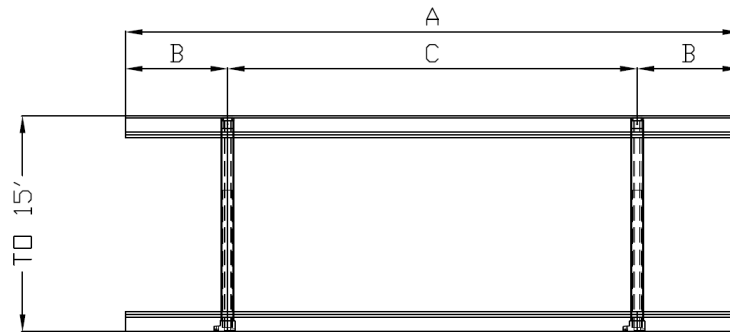

HEAVY DUTY
WALER RAIL

TABLE 1-2 CYLINDER WALER RAIL			
Model #	A (ft)	B (ft)	C (ft)
WRH-08	8	0.5	7
WRH-10	10	1	8
WRH-12A	12	2	8
WRH-12B	12	0.75	10.5

TABLE 2- 2 Cylinder Waler Rail Selection for OSHA Soil Type A & B Soils							
Depth of Excavation (ft)	Waler		Cylinder			Sheeting	
	Minimum Vertical Spacing (ft)	Waler Model	Horizontal spacing (ft)	Width of Excavation			
				to 8'	8' to 12'	12' to 15'	Note
to 12'	4	WHR8	7	2"	2"	2" (Note 1)	1,2
	4	WRH-10	8	2"	2"	2" (Note 1)	1,2
	4	WRH-12A	8	2"	2"	2" (Note 1)	1,2
	4	WRH-12B	10.5	2"	2"	2" (Note 1)	1,2
12' to 16'	4	WHR8	7	2"	2" (Note 1)	2" (Note 1)	1,2
	4	WRH-10	8	2"	2" (Note 1)	2" (Note 1)	1,2
	4	WRH-12A	8	2"	2" (Note 1)	2" (Note 1)	1,2
	4	WRH-12B	10.5	2"	2" (Note 1)	2" (Note 1)	1,2
16' to 20'	4	WHR8	7	2"	2" (Note 1)	2" (Note 1)	3
	4	WRH-10	8	2"	2" (Note 1)	2" (Note 1)	3
	4	WRH-12A	8	2"	2" (Note 1)	2" (Note 1)	3

TABLE 3-2 Cylinder Waler Rail Selection for OSHA Soil Type C-60 Soils							
Depth of Excavation	Waler		Cylinder				Sheeting
	Minimum Vertical Spacing	Waler Model	Horizontal spacing	Width of Excavation			
(ft)	(ft)		(ft)	to 8'	8' to 12'	12' to 15'	Note
to 12'	4	WHR-8	7	2"	2"	2" (Note 1)	2
	4	WRH-10	8	2"	2"	2" (Note 1)	2
	4	WRH-12A	8	2"	2"	2" (Note 1)	2
	4	WRH-12B	10.5	2"	2"	2" (Note 1)	2
12' to 16'	4	WHR-8	7	2" (Note 1)	2" (Note 1)	2" (Note 1)	4
	4	WRH-10	8	3"	3"	3"	4
	4	WRH-12A	8	3"	3"	3"	4
	4	WRH-12B	10.5	3"	3"	3"	4
16' to 20'	4	WHR-8	7	3"	3"	3"	4
	4	WRH-10	8	3"	3"	3"	4
	4	WRH-12A	8	3"	3"	3"	4

TABLE 4-2 Cylinder Waler Rail Selection for OSHA Soil Type C-80							
Depth of Excavation	Waler		Cylinder				Sheeting
	Minimum Vertical Spacing	Waler Model	Horizontal spacing	Width of Excavation			
(ft)	(ft)		(ft)	to 8'	8' to 12'	12' to 15'	Note
to 12'	4	WHR-8	7	2"	2"	2" (Note 1)	4
	4	WRH-10	8	2"	2"	2" (Note 1)	4
	4	WRH-12A	8	2"	2"	2" (Note 1)	4
	4	WRH-12B	10.5	2"	2"	2" (Note 1)	4
12' to 16'	4	WHR-8	7	3"	3"	3"	5,6
	4	WRH-10	8	3"	3"	3"	5,6
	4	WRH-12A	8	3"	3"	3"	5,6
16' to 20'	4	WHR-8	7	3"	3"	3"	5,6
	4	WRH-10	8	3"	3"	3"	5,6
	4	WRH-12A	8	3"	3"	3"	5,6

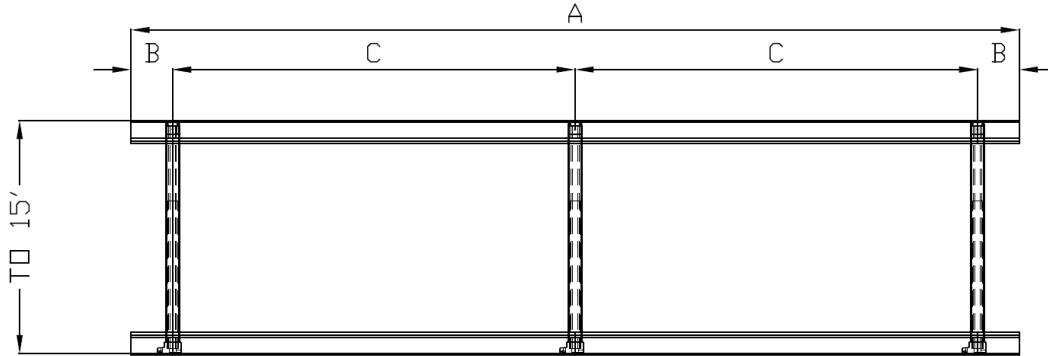

HEAVY DUTY
WALER RAIL

TABLE 5-3 CYLINDER WALER RAIL			
Model #	A (ft)	B (ft)	C (ft)
WRH2-12	12	0.75	5.25
WRH2-16	16	0.75	7.25
WRH2-20	20	0.75	9.25

TABLE 6-3 Cylinder Waler Rail Selection for OSHA Soil Type A & B Soils							
Depth of Excavation	Waler		Cylinder			Sheeting	
	Minimum Vertical Spacing	Waler Model	Horizontal spacing	Width of Excavation			
(ft)	(ft)		(ft)	to 8'	8' to 12'	12' to 15'	Note
to 12'	4	WRH2-12	5.25	2"	2"	2" (Note 1)	1,2
	4	WRH2-16	7.25	2"	2"	2" (Note 1)	1,2
	4	WRH2-20	9.25	2"	2"	3"	1,2
12' to 16'	4	WRH2-12	5.25	2"	2" (Note 1)	2" (Note 1)	1,2
	4	WRH2-16	7.25	2"	2" (Note 1)	3"	1,2
	4	WRH2-20	9.25	2"	2" (Note 1)	3"	1,2
16' to 20'	4	WRH2-12	5.25	2"	3"	3"	3
	4	WRH2-16	7.25	3"	3"	3"	3
	4	WRH2-20	9.25	3"	3"	3"	3

TABLE 7-3 Cylinder Waler Rail Selection for OSHA Soil Type C60 Soils							
Depth of Excavation	Waler		Cylinder			Sheeting	
	Minimum Vertical Spacing	Waler Model	Horizontal spacing	Width of Excavation			
(ft)	(ft)		(ft)	to 8'	8' to 12'	12' to 15'	Note
to 12'	4	WRH2-12	5.25	2"	2"	2" (Note 1)	2
	4	WRH2-16	7.25	2"	2"	2" (Note 1)	2
		WRH2-20	9.25	2"	2"	3"	2
12' to 16'	4	WRH2-12	5.25	3"	3"	3"	4
	4	WRH2-16	7.25	3"	3"	3"	4
							4
16' to 20'	4	WRH2-12	5.25	2"	3"	3"	4
	4	WRH2-16	7.25	2"	3"	3"	4
							4

TABLE 8-3 Cylinder Waler Rail Selection for OSHA Soil Type C80 Soils							
Depth of Excavation	Waler		Cylinder			Sheeting	
	Minimum Vertical Spacing	Waler Model	Horizontal spacing	Width of Excavation			
(ft)	(ft)		(ft)	to 8'	8' to 12'	12' to 15'	Note
to 12'	4	WRH2-12	5.25	3"	3"	3"	4
	4	WRH2-16	7.25	3"	3"	3"	4
12' to 16'	4	WRH2-12	5.25	3"	3"	3"	5,6

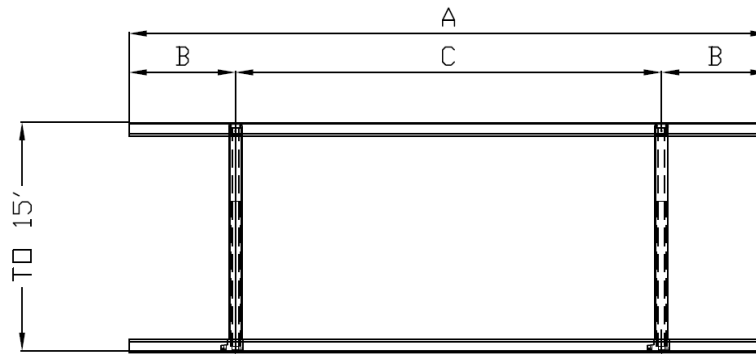

LIGHT DUTY
WALER RAIL

TABLE 9-2 CYLINDER WALER RAIL			
Model #	A (ft)	B (ft)	C (ft)
WRL-08	8	1	6
WRL-12	12	2	8

TABLE 10- 2 Cylinder Waler Rail Selection for OSHA Soil Type A & B Soils							
Depth of Excavation	Waler		Cylinder			Sheeting	
	Minimum Vertical Spacing	Waler Model	Horizontal spacing	Width of Excavation			
(ft)	(ft)		(ft)	to 8'	8' to 12'	12' to 15'	Note
to 12'	4	WRL-8	6	2"	2"	2" (Note 1)	1,2
	4	WRL-12	8	2"	2"	2" (Note 1)	1,2
12' to 16'	4	WRL-8	6	2"	2" (Note 1)	2" (Note 1)	1,2
	4	WRL-12	8	2"	2" (Note 1)	2" (Note 1)	1,2
16' to 20'	4	WRL-8	6	2"	2" (Note 1)	2" (Note 1)	3
	4	WRL-12	8	2"	2" (Note 1)	2" (Note 1)	3

TABLE 11-2 Cylinder Waler Rail Selection for OSHA Soil Type C-60 Soils							
Depth of Excavation	Waler		Cylinder			Sheeting	
	Minimum Vertical Spacing	Waler Model	Horizontal spacing	Width of Excavation			
(ft)	(ft)		(ft)	to 8'	8' to 12'	12' to 15'	Note
to 12'	4	WRL-8	6	2"	2"	2" (Note 1)	2
	4	WRL-12	8	2"	2"	2" (Note 1)	2
12' to 16'	4	WRL-8	6	2" (Note 1)	2" (Note 1)	2" (Note 1)	4
	4	WRL-12	8	3"	3"	3"	4

TABLE 12-3 CYLINDER WALER RAIL			
Model #	A (ft)	B (ft)	C (ft)
WRL-2-12	12	1	5
WRL2-16	16	2	6

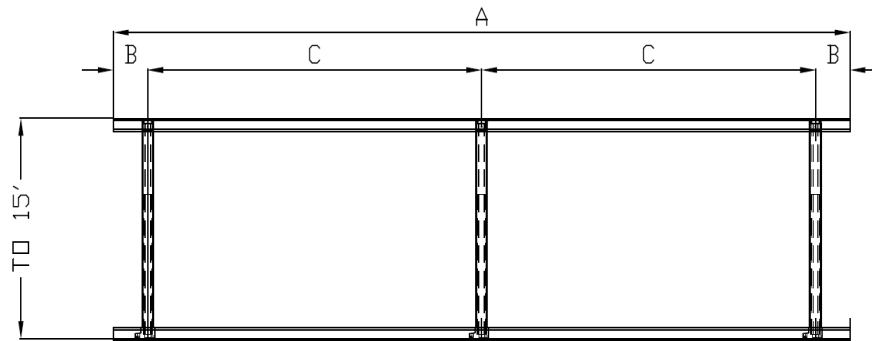

LIGHT DUTY
WALER RAIL

TABLE 13-3 Cylinder Waler Rail Selection for OSHA Soil Type A & B Soils

Depth of Excavation	Waler		Cylinder				Sheeting
	Minimum Vertical Spacing	Waler Model	Horizontal spacing	Width of Excavation			
(ft)	(ft)		(ft)	to 8'	8' to 12'	12' to 15'	Note
to 12'	4	WRL3-12	5	2"	2"	2" (Note 1)	1,2
	4	WRL3-16	6	2"	2"	2" (Note 1)	1,2
12' to 16'	4	WRL3-12	5	2"	2" (Note 1)	2" (Note 1)	1,2
	4	WRL3-16	6	2"	2" (Note 1)	2" (Note 1)	1,2
16' to 20'	4	WRL3-12	5	2"	2" (Note 1)	2" (Note 1)	3
	4	WRL3-16	6	2"	2" (Note 1)	2" (Note 1)	3

TABLE 14-3 Cylinder Waler Rail Selection for OSHA Soil Type C60 Soils

Depth of Excavation	Waler		Cylinder				Sheeting
	Minimum Vertical Spacing	Waler Model	Horizontal spacing	Width of Excavation			
(ft)	(ft)		(ft)	to 8'	8' to 12'	12' to 15'	Note
to 12'	4	WRL3-12	5	2"	2"	2" (Note 1)	2
	4	WRL3-16	6	2"	2"	2" (Note 1)	2
12' to 16'	4	WRL3-12	5	3"	3"	3"	4
	4	WRL3-16	6	3"	3"	3"	4

WALER RAIL GEOMETRIC PROPERTIES

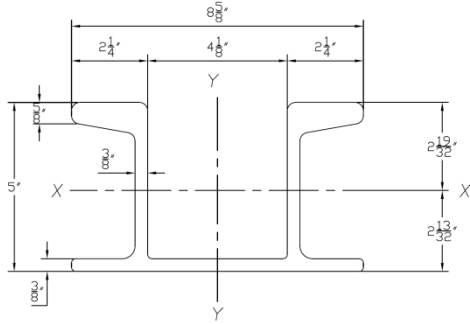

HEAVY DUTY
WALER RAIL

AREA	= 9.57 IN ²
WEIGHT	= 11.5 PLF
MOMENT OF INERTIA	= 36.34 IN ⁴
SECTION MODULUS TOP	= 14.0 IN ³
SECTION MODULUS, BOTTOM	= 15.1 IN ³
RADIUS OF GYRATION	= 1.95 IN

Material 6061T6 Aluminum

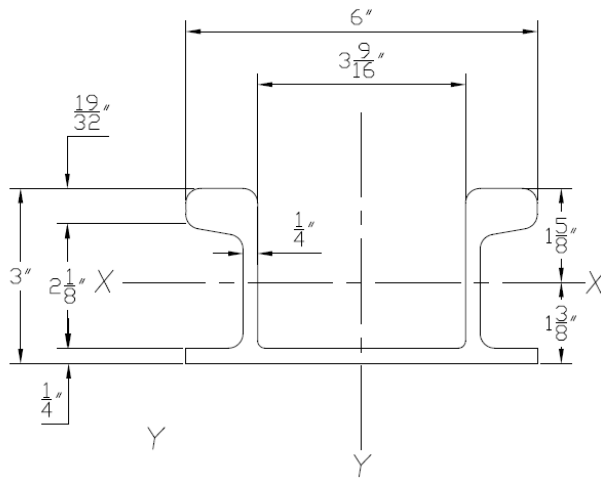
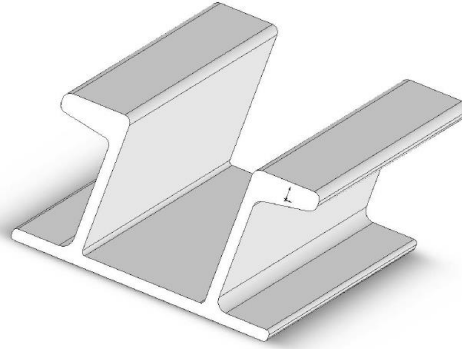

LIGHT DUTY
WALER RAIL

AREA	= 4.34 IN ²
WEIGHT	= 11.5 PLF
MOMENT OF INERTIA	= 5.64 IN ⁴
SECTION MODULUS TOP	= 3.47 IN ³
SECTION MODULUS, BOTTOM	= 4.1 IN ³
RADIUS OF GYRATION	= 1.13 IN
MATERIAL	6061-T6 ALUMINUM

WALER SYSTEM SHORE INSTALLATION AND REMOVAL PROCEDURE

Required for installation

- Vertical Hydraulic Jack
- Pump with fluid and operating pressure gauge
- Release tool

Installation Procedure

- Step 1 Attach hydraulic hose to hydraulic fitting on shore. Open the valve on the pump can so that the shore cannot be pressurized. Set plywood if required and not attached to the shore into trench.
- Step 2 Lower shore into trench. Heavy or wide shores that cannot be safely lifted by one person should be set in with lifting equipment such as backhoe, boom truck or crane.
- Step 3 Close the valve on the pump can and pressurize the hydraulic shore to between 750 and 1500 psi. Pressure gauge should hold at pressure and not indicate any loss of pressure.
- Step 4 Remove the hydraulic hose by prying off with release tool. Clip hose to top of pump to prevent contamination by dragging it in the dirt. Move to next shore location and repeat process.

While trench shores are in place

- Check at least at start of shift for loose shores. This can be done by tapping the top of the shore with a metal rod; it will sound loose, sort of like kicking a tire to see if it is flat. Remove and replace loose shores.
- Check for sloughing or raveling. If it is occurring, sheeting must be used.
- Confirm that soil classification has not changed.

Required for Removal

- Vertical Hydraulic Shore
- Release tool
- Removal tool or lifting equipment

Removal Procedure

- Step 1 Place release tool over hydraulic fitting and removal hook in handle on opposite blade.
- Step 2 Push release to away to release fluid and pressure. Pull up on the removal hook to fold the shore up and then lift it out of trench.

Note - Depending on the length of the shore and width of the trench different installation procedures may be used. It is the responsibility of the contractor and his competent person to establish a safe installation and removal procedure for each application. All trench shore installers shall be instructed in the procedure prior to installing the shores.